



HPTO12H

Microprocessor Controlled Hydraulic Clutch

Clutch Controller

The microprocessor based clutch controller allows for a consistent startup process every time, extending the life of the clutch.

The BASIC2 controller can be integrated into the equipment's control system the SAE J1939 CAN-bus protocol.

The start-up sequence (patent software) involves a series of pulses delivering up to 200% peak engine torque. This means the HPTO12H can start equipment with significant inertia or even under partially jammed conditions.

The HPTO12H package increases equipment reliability and profitability with a consistent startup process every time.

For application or technical assistance please contact PTTech.

The HPTO12H is a hydraulically applied dry friction clutch for diesel engine applications. Its hydraulic design eliminates the need to adjust the clutch throughout its wear life. The HPTO12H comes in both SAE (HPTO12TD) and Metric (HPTO12TS) configurations.

Features and Benefits:

No engine pilot bearing

No adjusting or greasing required

Self-adjusting for wear

Designed to absorb shockloads

Internal rotary union allows for inline applications

Includes clutch controller that monitors and reports clutch status

"Push button" clutch engagement
Can be engaged remotely
(no mechanical Level)

SAE J1939 CAN
Communications

Hydraulic/Electrical System

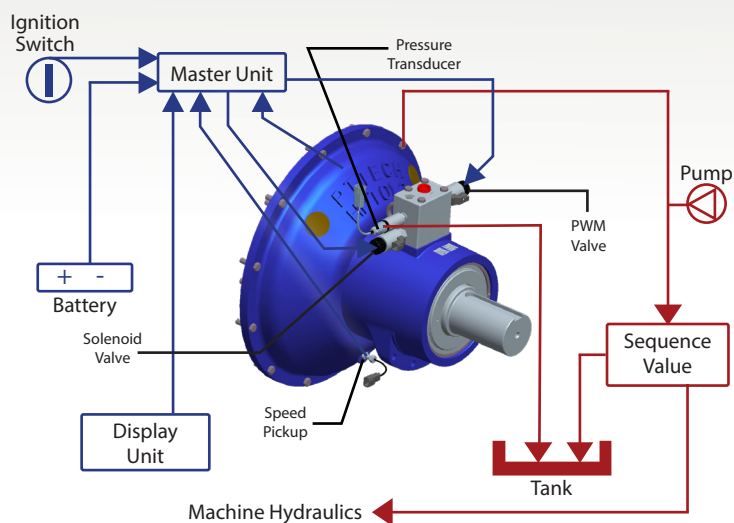

HPTO12H DIMENSIONAL DATA

		SAE HPTO12HTD	METRIC HPTO12HTS
		Inches	MM
A	Overall Length	22.08	494.3
D	Useable Key Length	6.31	124.2
E	Useable Shaft Length	6.875	142.9
F	Shaft Diameter	3.5	90
H	Shaft Centerline to Manifold Top	11 1/2	292.1

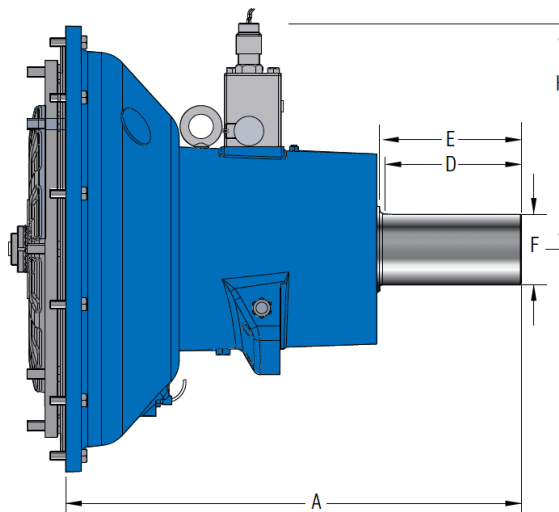

HPTO12H PRODUCT SPECIFICATIONS

Power & Max.	460-600 Hp	343-447 kW
Max. Engine Torque	2225 lb-ft	3016 nM
Max. Speed	2,250 RPM	
Pressure	400-1,000 PSI	28-70 bar
Weight	440 lbs	200 kg
Housing	SAE #1	
Mounts to	SAE 14 Flywheel	

PT TECH'S HPTO CLUTCHES

DRY CLUTCH FAMILY

HPTO8	80-140 Hp	59-104 kW
HPTO10	140-250 Hp	104-186 kW
HPTO12	250-460 Hp	186-343 kW
HPTO12H	460-600 Hp	343-447 kW

WET CLUTCH FAMILY

HPTO13	250-475 Hp	186-354 kW
HPTO14	475-765 Hp	354-570 kW
HPTO15	765-1050 Hp	570-783 kW
HPTO21	1050-1600 Hp	783-1193 kW