

HPTO30

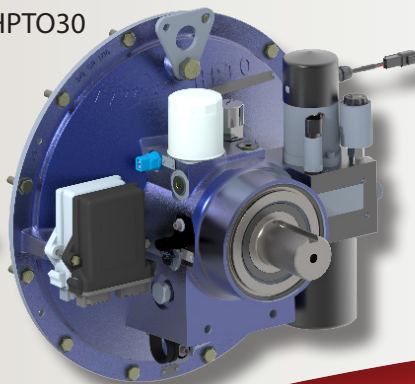

HPTO32

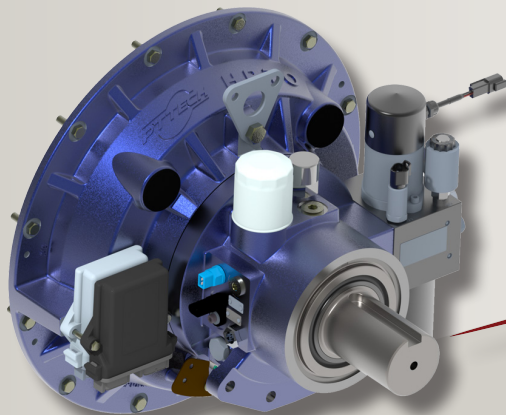

HPTO34

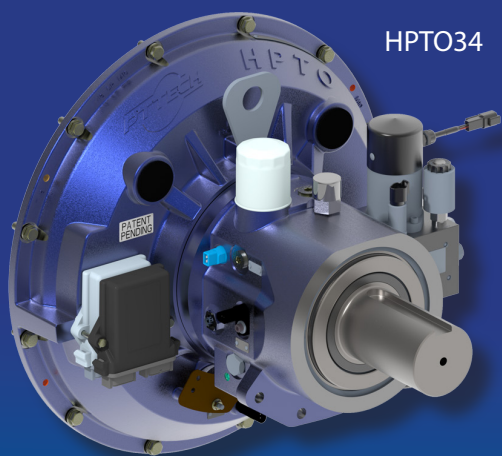

HPTO[®] GEN3

Dry Microprocessor Controlled Hydraulic Clutch

The best in class gets even more robust!

DROP-IN OR FULLY INTEGRATED

The standard offerings can drop right into existing applications. The integrated options include a fully integrated system with a sump, pump, manifold valves, and filtration system. The controller and clutch wiring is provided with the clutch. Plug in communication, small cooler, add power, and the clutch is ready to go!

SIMPLIFIED TROUBLESHOOTING

This new series of clutches makes troubleshooting simplified! A new controller design and HPTOLink App allows for data logging and remote connection for downloading fault logs to send to PT Tech support. If you choose the fully integrated model, it means near isolation from the machine, simplifying fault modes. All of this creates opportunities to that make it easier to support machines all around the globe

VALUE ADDITIONS

In addition to the above benefits, the HPTO[®] Gen3 is also easier for engineering and purchasing. There are 4 total clutch models, instead of the 11 models of the previous generation. One bearing design eliminates TD and DD versions, with increased belt-load capacity. The smaller and lower cost models are now at higher HP ranges as well. Common service kits allow for faster and easier servicing.

All of these benefits come together on the Gen3 series clutches to simplify integration, reduce duplication, increase performance, improve communication, and minimize downtime.

For application or technical assistance please contact PT Tech for more information.

WHAT'S NEW:

- Increased power density allows for smaller clutches to manage more power
- Even more robust bearing arrangement allows one clutch for both direct and transverse drives
- Option for PTT integrated hydraulics package
- Improved & adaptive controls logic running on next gen controller hardware
- Compatibility with new HPTO smartphone App

HPTO
LINK



HPTO[®] GEN3

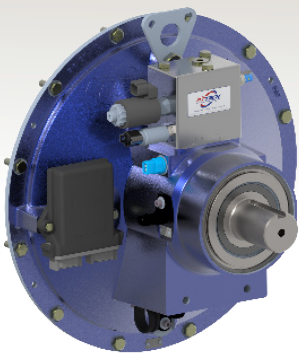

HPTO30

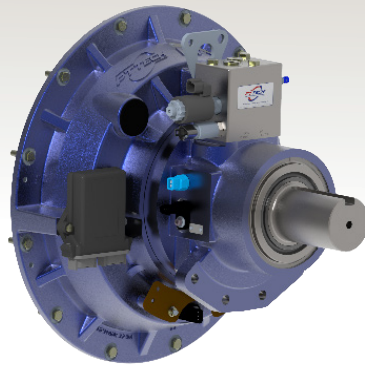

HPTO32

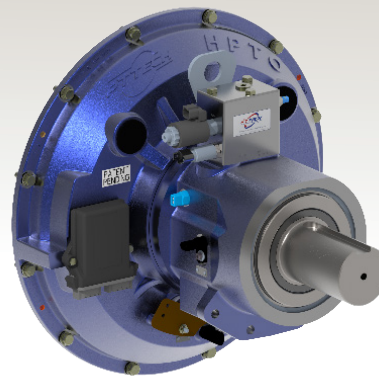

HPTO34

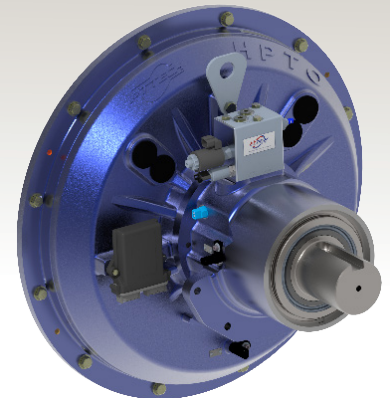

HPTO36

PRODUCT SPECIFICATIONS

	HPTO30	HPTO32	HPTO34	HPTO36
Engine Power	80 - 200 Hp	140 - 460 Hp	380 - 800 Hp	540 - 1,200 Hp
Max Engine Torque	600 lb-ft	1,825 lb-ft	2,800 lb-ft	4,500 lb-ft
Max Speed	3,200 RPM	2,500 RPM	2,250 RPM	2,250 RPM
Inlet Pressure	400 - 3,000 PSI	400 - 3,000 PSI	400 - 3,000 PSI	400 - 3,000 PSI
Weight	170 lbs	280 lbs	450 lbs	816 lbs
Engine Housing	SAE #3	SAE #3, #2, & #1	SAE #1 & #0	SAE #0
Engine Flywheel	SAE 11.5	SAE 11.5 & 14	SAE 14	SAE 18

DIMENSIONAL DATA

INCHES	30	32	34	36
Overall Length (in)	18.0	16.1	22.1	21.8
Useable Shaft Length (in)	6.88	6.50	6.88	5.12
Shaft Diameter (in)	2.50	2.50	3.50	4.50

HPTO GEN3 CLUTCH FAMILY

DRY CLUTCH FAMILY

HPTO30	80 - 200 Hp	60 - 149 kW
HPTO32	140 - 460 Hp	105 - 343 kW
HPTO34	380 - 800 Hp	283 - 597 kW
HPTO36	540 - 1,200 Hp	403 - 895 kW

WET CLUTCH FAMILY - with pump towers

HPTO31	80 - 350 Hp	60 - 261 kW
HPTO33	320 - 800 Hp	239 - 597 kW
HPTO35	320 - 920 Hp	239 - 686 kW
HPTO37	800 - 1,200 Hp	597 - 895 kW