

FMD Torque Limiter Series

- Fixed Multiple Disc
- High Torque
- High Energy

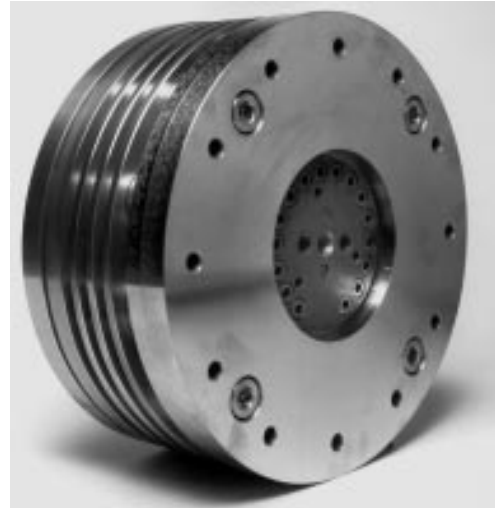

FMD Torque Limiter Series

PT Tech's FMD series is a friction-type multiple disc torque limiter for high horsepower, high energy and/ or limited space applications. They are designed to operate on the high speed side of a drive system. There are four sizes within the FMD series. Their physical characteristics are outlined in the Dimensional Data chart (see Table #2). Units larger and smaller are available.

The FMD torque limiter can be manufactured to accommodate either the Renold Hi-Tec PM Series Elastomeric Couplings (see Figure #3 on back side) or the American Vulkan Flexomax-GS Series Couplings (see Figure #4 on back side). This combines torque limiting with misalignment and vibration damping capability all in one package.

The torque setting of an FMD torque limiter is controlled by quantity and strength of the spring-cups. The operating characteristics are outlined in the Performance Data chart (see Table #1). The torque setting of any FMD torque limiter is easily verified by checking the quantity and color of spring-cup assemblies.

Applications requiring special consideration is PT Tech's business. For assistance, call our Engineering Department.

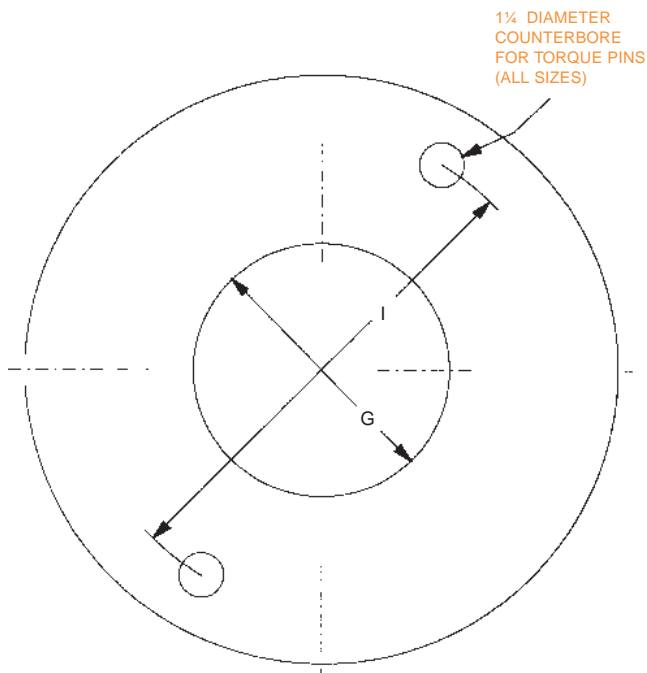

Figure #1

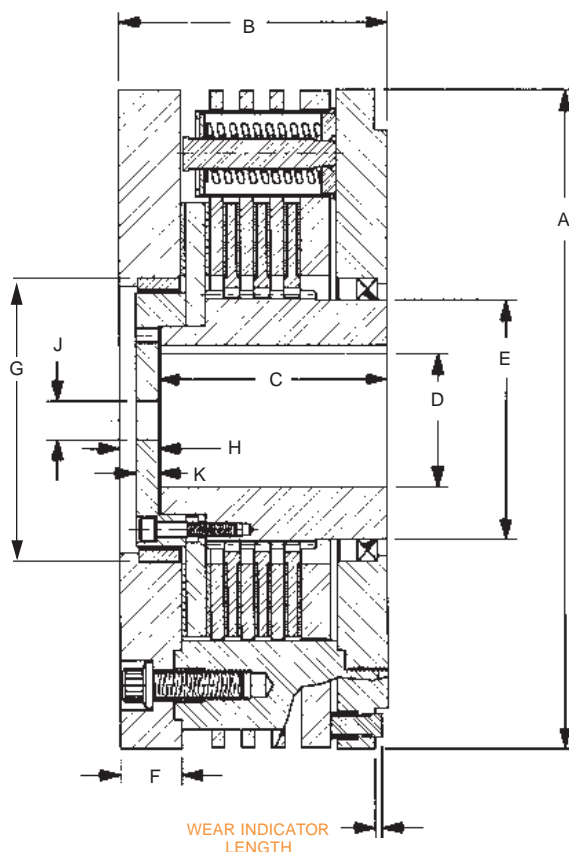

Figure #2

PT Tech 1441 WOLF CREEK TRAIL, P.O. BOX 305
 SHARON CENTER, OH 44274-0305
 POWER TRANSMISSION TECHNOLOGY INC. TEL (330) 239-4933 • FAX (330) 239-2012

FMD TORQUE LIMITER SERIES

5/98

EDS - FMD

Table #1

PERFORMANCE DATA*					
FMD SERIES		23	28	36	44
Maximum torque **	lb-ft (Nm)	6,368 (8,624)	7,640 (10,352)	15,168 (20,544)	25,552 (34,752)
Max quantity spring-cups		8	8	12	16
Torque per spring-cup:					
BLUE	lb-ft (Nm)	796 (1,078)	955 (1,294)	1,264 (1,712)	1,597 (2,172)
RED	lb-ft (Nm)	525 (711)	631 (855)	834 (1,130)	1,054 (1,433)
SILVER	lb-ft (Nm)	355 (481)	430 (583)	569 (771)	718 (976)
GREEN	lb-ft (Nm)	159 (215)	191 (258)	253 (343)	319 (434)
Maximum speed	RPM	3,450	3,450	2,500	2,050
Inertia - complete torque limiter w/o coupling	lb-ft ² (kgm ²)	44 (1.85)	71 (2.99)	178 (7.49)	365 (15.38)
Inertia - torque limiter output only	lb-ft ² (kgm ²)	1.64 (.07)	5.89 (.25)	12.37 (.52)	35.4 (1.49)
Torque limiter weight	lbs. (kg)	220 (100)	330 (150)	550 (250)	900 (409)

* All dimensions are subject to change without notice.

** Max torque can be greater in certain low speed (<450 RPM) applications. Consult PT Tech.

Inches (millimeters)

Table #2

DIMENSIONAL DATA* See Figures #1 & 2					
FMD SERIES		23	28	36	44
A	in. (mm)	14.50 (368.3)	16.50 (419.1)	20.13 (511.3)	23.75 (603.3)
B	Torque limiter length	6.57 (166.9)	6.67 (169.4)	7.16 (181.9)	7.16 (181.9)
C	Output hub length***	5.53 (140.5)	5.65 (143.5)	6.00 (152.4)	6.00 (152.4)
D	Max bore****	3.35 (85.0)	4.33 (110.0)	5.375 (136.5)	7.375 (200)
E	Output hub diameter	5.03 (127.7)	6.03 (153.1)	6.75 (171.5)	10.25 (260.4)
F	Input flange thickness	1.55 (39.4)	1.52 (38.6)	1.85 (47.0)	1.85 (47.0)
G	Bearing clearance diameter	6.25 (158.8)	7.375 (187.3)	8.25 (209.6)	12.25 (311.2)
H	Min DBSE	1.04 (26.4)	1.02 (25.9)	1.16 (29.5)	1.43 (36.3)
I	Torque pin bolt circle	11.50 (292.1)	13.33 (338.5)	17.00 (431.8)	20.50 (520.7)
Number of torque pins		4	4	6	8
KEEPER PLATE**					
J	customer specified per application				
K	Thickness	.62 (15.7)	.73 (18.5)	.73 (18.5)	.73 (18.5)

* All dimensions are subject to change without notice.

** Request toleranced dimension for the purpose of machining or modifying keeper plate.

*** Extended length output hubs are available.

**** If larger bore is required, consult PT Tech.

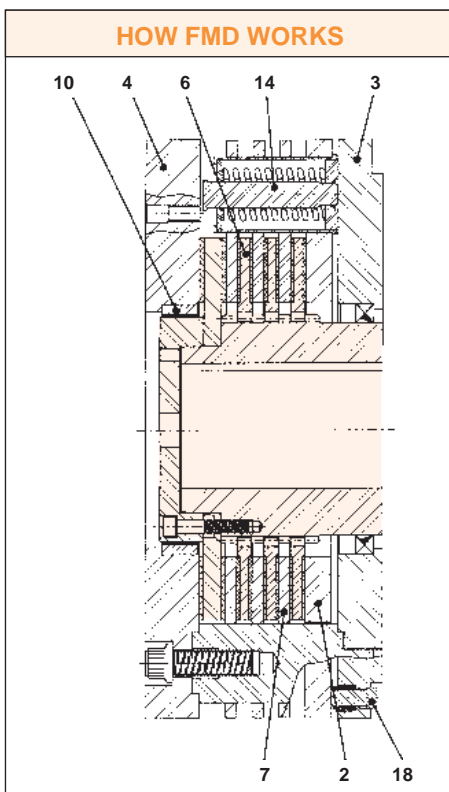

The FMD series friction-type torque limiters require no adjustment at installation or throughout their entire wearlife. They require no lubrication and no resetting after slip has occurred. Wear can be accurately and readily measured without disturbing the unit.

A complement of spring cup assemblies (Item #14) exert a force pushing the pressure plate (Item #2) away from end plate "B" (Item #3). This places a clamping force between the friction plates (Item #6) and the separator plates (Item #7). Torque is transmitted from the input end plate (Item #4) through the separator plates to the friction plates. The friction plates are engaged to the bored output hub through closely toleranced splines. The entire output of the torque limiter is shaded.

A FMD Series torque setting is preset at

the factory. When the drive system torque exceeds the setting, the torque limiter will slip while continuing to transmit torque equal to the setting. This is possible because the static and dynamic coefficient of friction of the disc pack is close to being the same.

The FMD series torque limiter is designed to operate at motor speed. In most drive systems the prime mover represents approximately 80-90% of the equivalent inertia. The FMD series will generally provide excellent inertial shockload protection when located at the prime mover.

For more complete information on inertial shockloads, request PT Tech's "Torque Protection for Electric Motor Driven Equipment" brochure.

FMD WITH RENOLD HI-TEC PM COUPLING

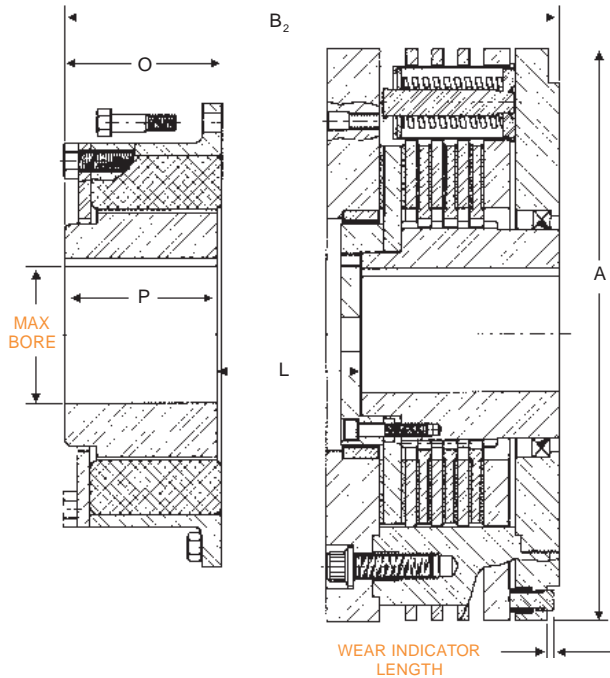

Figure #3

FMD WITH AMERICAN VULKAN GS COUPLING

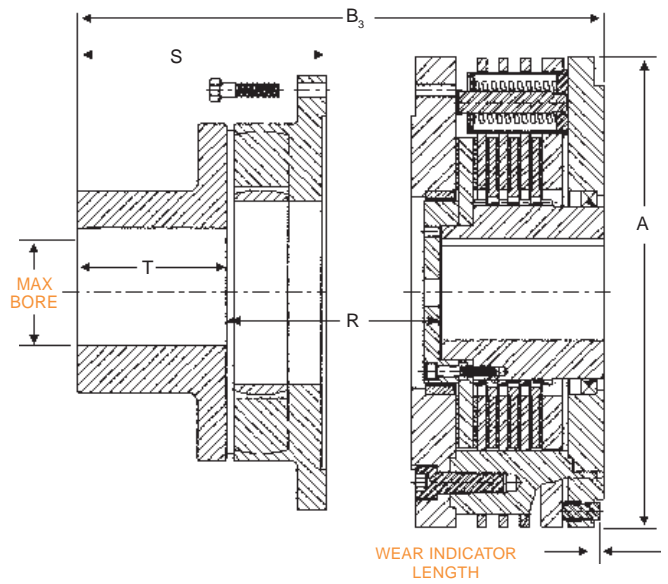

Figure #4

Inches (millimeters)

Table #3

FMD TORQUE LIMITER SIZE					
FMD SERIES		23	28	36	44
A	Outside diameter	14.50 (368.3)	16.50 (419.1)	20.13 (511.3)	23.75 (603.3)
B ₂	Overall length	11.0 (279.4)	11.10 (281.9)	12.97 (329.4)	14.70 (373.4)
L	DBSE*	1.18 (29.9)	1.16 (29.4)	1.34 (34.0)	1.38 (35.0)
O	Coupling length	4.43 (112.5)	4.43 (112.5)	5.81 (147.6)	7.54 (191.5)
P	Hub length	4.29 (109.0)	4.29 (109.0)	5.63 (143.0)	7.32 (185.9)
	Max bore	4.29 (109.0)	4.29 (109.0)	5.63 (143.0)	7.32 (185.9)
RENOLD HI-TEC**		PM 12	PM 12	PM 27	PM 60
	Part number	U10368/00	U10368/00	U10369/00	U10374/00
Renold Hi-Tec Coupling	lb-ft ² inertia (kgm ²)	8.85 (.37)	8.85 (.37)	33.92 (1.43)	126.8 (5.34)
Renold Hi-Tec Coupling	lbs. weight (kg)	74 (34)	74 (34)	166 (75)	368 (167)

* DBSE - Distance between shaft ends

** Refer to Renold Hi-Tec Coupling flex half for all sizes
Renold Hi-Tec Engineering Co. 1-800-850-8141

Inches (millimeters)

Table #4

FMD TORQUE LIMITER SIZE					
FMD SERIES		23	28	36	44
A	Outside diameter	14.50 (368.3)	16.50 (419.1)	20.13 (511.3)	23.75 (603.3)
B ₃	Overall length	13.83 (351.3)	15.15 (384.8)	17.79 (451.9)	18.26 (463.8)
R	DBSE*	3.88 (98.6)	4.32 (109.7)	5.02 (127.5)	5.30 (134.6)
S	Coupling length	7.38 (187.5)	8.60 (218.4)	10.75 (273.1)	11.22 (285.0)
T	Hub length	4.43 (112.5)	5.18 (131.6)	6.77 (172.0)	7.22 (183.4)
	Max bore	5.00 (127.0)	5.75 (146.1)	7.50 (190.5)	9.50 (241.3)
AMERICAN VULKAN COUPLING SIZE**		GSNX 260	GSNX 300	GSNX 360	GSNX 400
American Vulkan Coupling	lb-ft ² inertia (kgm ²)	10.44 (.400)	22.21 (.936)	63.83 (2.690)	111.22 (4.687)
American Vulkan Coupling	lbs. weight (kg)	107 (48)	171 (77)	340 (153)	462 (208)

* DBSE - Distance between shaft ends

** Refer to American Vulkan Flexomax-GS for all sizes
American Vulkan Corp. 1-800-993-2424

IMPORTANT FEATURES

High Energy Capacity

The end plates, separator plants and pressure plate (Items #2,3,4, and 7) provide a large mass and surface area to absorb and dissipate heat due to torque limiter slippage. For applications where extensive slippage is anticipated, consult PT Tech for energy capacity data.

No Adjustment at Installation

Torque limiter torque is preset. Problems due to improper adjustment at installation are virtually eliminated.

No Adjustment Throughout Entire Wearlife

Unique spring-cup design provides consistent force on the friction surfaces as they wear. Problems due to improper adjustment by maintenance personnel are eliminated.

Tamper-resistant Torque Setting

Torque can only be varied by disassembling the torque limiter and changing the strength or quantity of spring-cups (Item #14).

Wide Range of Torque Settings

Torque capacity can be precisely set by selecting quantity and strength of spring-cups.

Accommodates a Wide Variety of Couplings

The input endplate (Item #4) can be easily modified to accept a variety of couplings and universal joint drive shafts.

Torque Setting Easily Checked

Color-coded spring-cups allow quick verification of torque setting. Special equipment and testing to check torque setting is eliminated.

No Maintenance

No lubrication and no adjustment feature virtually eliminate periodic maintenance.

Graphited Bronze Bearing

Permanently lubricated for long maintenance-free life (Item #10).

Friction Wear Easily Checked

The wear indicated (Item #18) allows quick check of remaining wearlife.

Low Output Inertia

Provides excellent control of inertial shockloads.

Insulated Springs

Springs are insulated from torque limiter heat to protect against thermal relaxation of spring pressure.

Easy Installation

The FMD Torque Limiter is shipped fully assembled. It is as easy to install as a flexible coupling.

WARRANTY: PT Tech guarantees all its products will leave the factory in good condition. PT Tech warrants its products against defects in workmanship and material for a period of 365 days (one year) after shipment. Adjustments under this warranty will be made only after completion of inspection of the part or product in PT Tech's factory. PT Tech's liability under the warranty shall extend only to the replacement or correction of any defective part or product determined by PT Tech's inspection as not conforming to this warranty. Under no circumstances shall PT Tech be liable for consequential or incidental damages. This warranty shall not apply to any product which shall have been repaired or altered without PT Tech's knowledge and consent or operated or installed contrary to PT Tech's instruction or subjected to misuse, improper maintenance, or damaged by accident or negligence.

PERFORMANCE ASSURANCE: Rated torque and speeds are provided by PT Tech to assist the buyer in selecting the proper product. In addition, engineering assistance is offered by PT Tech for design and application of custom designed drives. Since the actual performance characteristics of the buyer's equipment cannot be completely analyzed nor duplicated in laboratory tests, performance assurance of all PT Tech products in the buyer's applications is the responsibility of the buyer. Performance assurance is usually accomplished through manufacture of a prototype by PT Tech and a test or qualification program on the part of the buyer.

Rotating equipment is potentially dangerous and should be properly guarded. The user should check all applicable safety codes in his area and provide suitable guards.

PRELIMINARY SELECTION PROCEDURE*

A friction-type torque limiter is both a torque and an energy device. The following preliminary selection procedure identifies the torque limiter size based strictly on torque requirements. Torque setting should be above the motor's peak torque. This allows the motor to fully draw upon its peak torque capability during heavily loaded situations without slipping the torque limiter. If torque setting needs to be below peak motor torque, contact PT Tech.

1) Determine Running Torque (T_R)

$$T_R = (\text{HP} \times 5,250) / \text{RPM}$$

2) Determine Max Torque

This information can be obtained from motor manufacturer. Typically, NEMA B motors have max torque that is 250% greater than T_R

3) Determine Torque Setting (T_S)

$$T_S = \text{Max Torque} \times 1.50$$

4) Preliminary Selection Based on

- torque setting (T_S)
- bore requirement
- max speed

5) Consult with PT Tech to correctly match application energy requirement and torque limiter energy capacity.

6) For diesel or Turbine applications consult PT Tech.

** This procedure is STRICTLY intended as a general guideline. Consult PT Tech to finalize selection.*

For reversing applications consult PT Tech.

APPLICATION ENGINEERING ASSISTANCE

PT Tech has analyzed hundreds of drive systems in many types of equipment and industries. Our torque control expertise is available to our customers at no charge to help engineer possible torque protection.

PT Tech can provide a computerized report that analyzes your drive system and helps determine the need for torque protection. The computer generates a torque analysis graph comparing the maximum torque in the drive system, with and without a TLC torque limiter, under various jam conditions.

Also, PT Tech has developed a unique test stand that can simulate shockloads generated by the inertia of motors up to 2,500 HP.