

Adjusting for wear is easy. When the armature gap indicator has recessed approximately 1/16 inch, return it to the flush position by turning the wear adjustment nut.

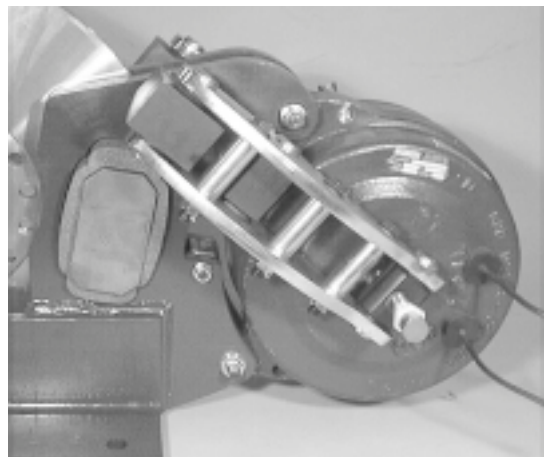

Caliper arms swing up exposing friction pucks for easy removal and replacement.

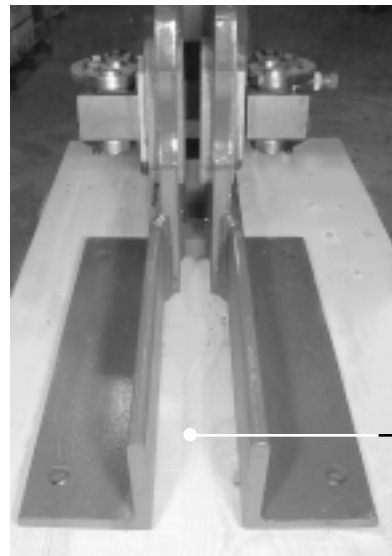

* Installation requires no modification, when mounting bolt hole pattern meets AISE Brake Standard #11. Centerline of the disc maintains the same position relative to the motor as the center line of drum.

Patented slotted base allows the CDB-A to be installed fully assembled.

CDB1924A and CDB2329A CALIPER DISC BRAKES

- *Spring applied, electrically released*
- *Operates in series or shunt*
- *Installation requires no modification**
- *Conforms to new AISE Brake Standard #11*

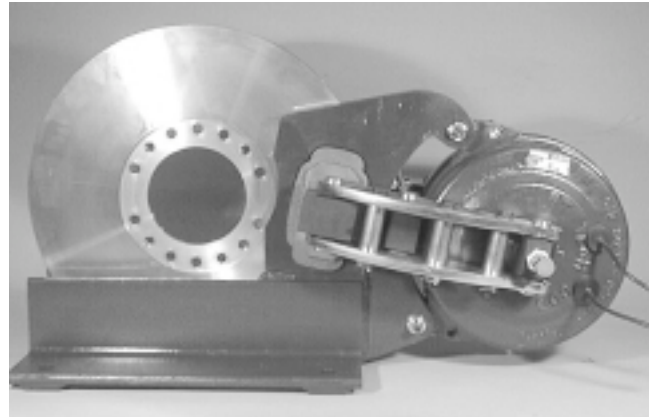

The PT Tech CDB-A Caliper Disc Brakes are designed to upgrade cranes to the higher performance and the ease of maintenance of a caliper disc brake. Upgrading to the PT Tech Caliper Disc Brake will result in the following advantages.

- 1) Wear adjustment is far easier.
- 2) Less frequent need for wear adjustments.
- 3) Improved wear life.
- 4) Replacing friction pucks is substantially quicker.
- 5) Friction pads weigh far less than drum brake shoes.
- 6) Eliminates drag and slip problems due to drum thermal expansion.
- 7) Eliminates heat checking.
- 8) Sealed coil design reduces periodic cleaning maintenance.
- 9) Sealed design reduces shockload.

CDB-A Brakes conform to the new AISE Brake Standard published in August, 1997.

| MAXIMUM TORQUE (lb-ft) | | | | |
|------------------------|--------------|--------|-------------|--------|
| Brake | SERIES WOUND | | SHUNT WOUND | |
| | ½ hour | 1 hour | ½ hour | 1 hour |
| 1924A | 2000 | 1300 | 2000 | 1500 |
| 2329A | 4000 | 2600 | 4000 | 3000 |

| | | | |
|--|--|--|-------------|
|  | 1441 WOLF CREEK TRAIL, P.O. BOX 305 SHARON CENTER, OH 44274-0305 TEL (330) 239-4933 • FAX (330) 239-2012 | | |
| | CDB-A Caliper Disc Brake | | |
| 10/00 | | | EDS - CDB-A |

www.pttech.com

DIMENSIONAL DATA • BRAKE

| DIMENSIONS ARE IN INCHES | CDB1924 A | CDB2329A |
|--------------------------|-----------|----------|
| A | 24.00 | 29.00 |
| H | 13.25 | 15.88 |
| L | 6.50 | 8.00 |
| M | 8.00 | 9.64 |
| N | 1.06 | 1.31 |
| P | 9.25 | 11.75 |
| Q | 11.50 | 14.50 |
| R | 13.36 | 17.34 |
| S | 12.00 | 14.50 |
| T | 30.10 | 36.66 |
| U | 9.70 | 9.70 |
| V | 25.25 | 30.38 |
| W | 8.10 | 8.47 |
| X | 19.70 | 23.28 |
| Z | 1.50 | 2.13 |

PERFORMANCE DATA • BRAKE

| | CDB1924 A | CDB2329 A |
|---|-------------------------|-------------------------|
| Energy Capacity ft-lbs/hr ¹ | 10,000,000 ¹ | 15,000,000 ¹ |
| Max Speed | 2,100 rpm | 1,740 rpm |
| Torque Rating ² | 2,000 lb-ft | 4,000 lb-ft |

¹ For high energy applications contact PT Tech about using ventilated discs.

² Higher torques and speeds are available. Consult PT Tech.

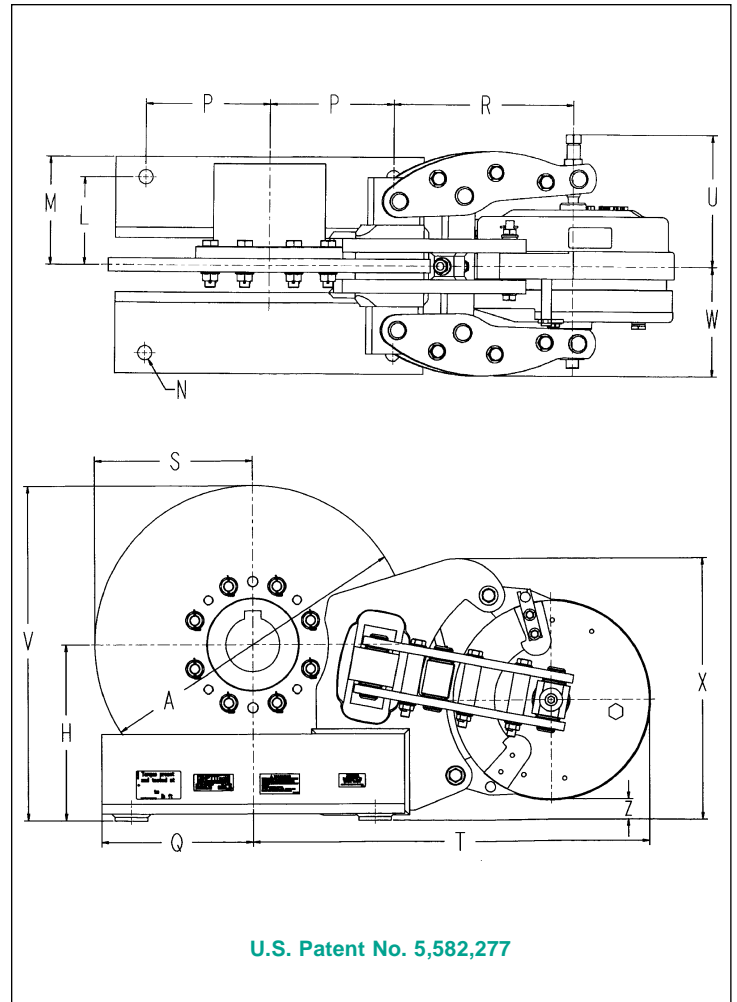

DIMENSIONAL COMPARISON

The following is a quick dimensional comparison between the CDB-A brakes and several drum brakes:

| | CDB1924A | | | | CDB2329A | | | |
|-------------|----------|-------|-------|-------|----------|-------|-------|-------|
| | PTT | P&H® | C-H® | SQ-D® | PTT | P&H® | C-H® | SQ-D® |
| T IN | 30.1 | 33.25 | 26.5 | 33.25 | 36.66 | 38.5 | 30.38 | 39.75 |
| V IN | 25.25 | 27.63 | 25.63 | 28.50 | 30.38 | 32.81 | 30.38 | 34.87 |

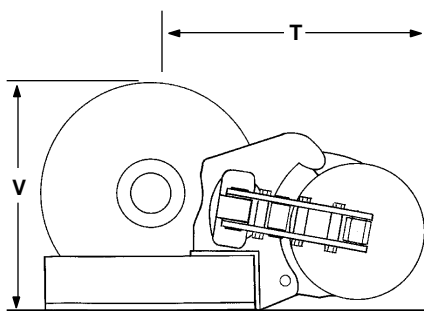

PT TECH

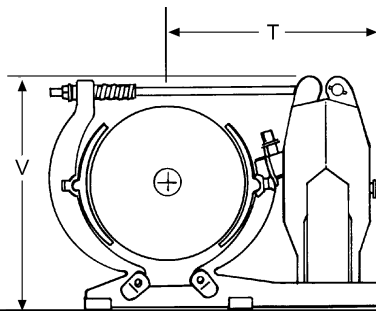

C-H

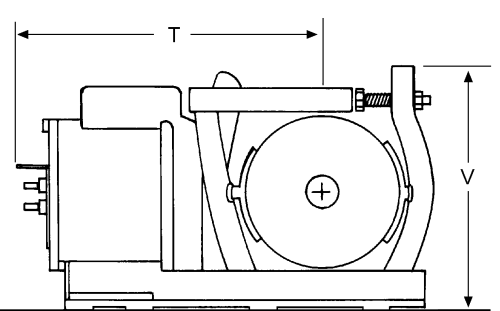

SQ-D and P-H

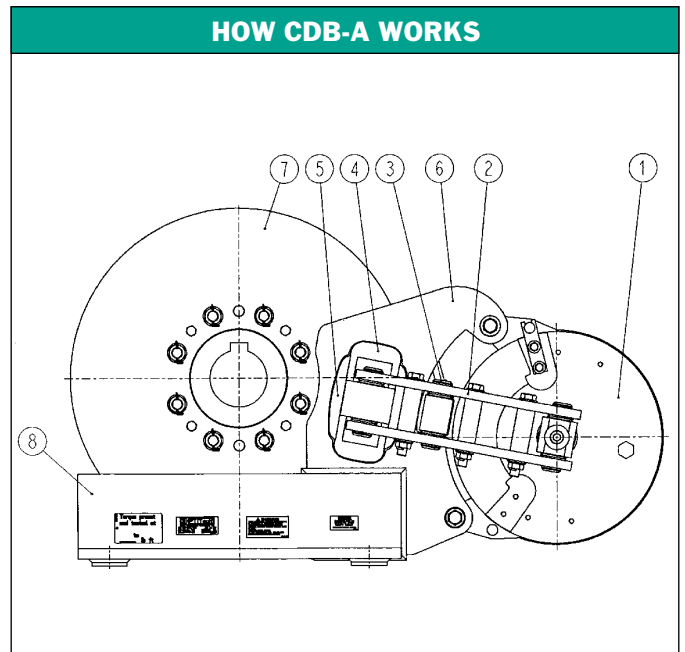
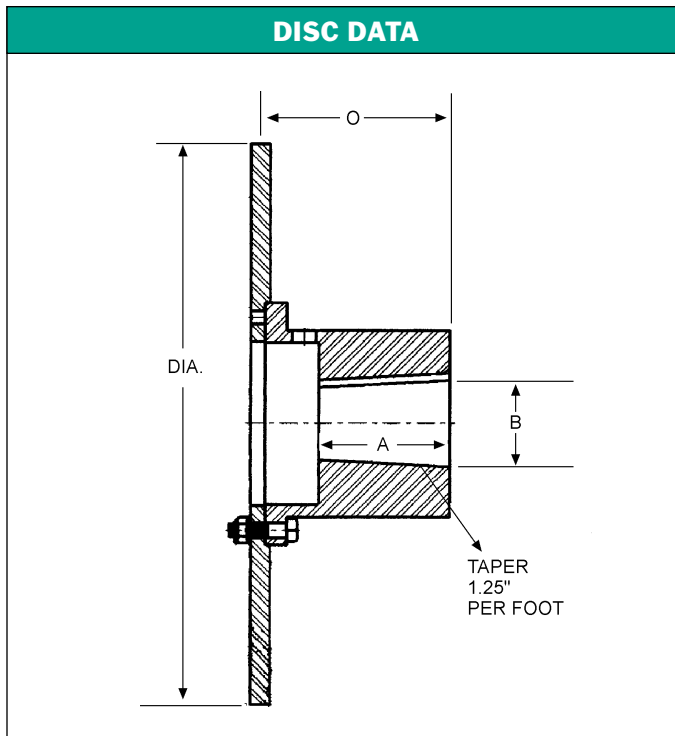

CDB-A brakes are spring applied and electrically released. When power is turned off the torque spring assembly pushes the armature away from the magnet body (#1) which in turn forces the caliper arms out.

The caliper arms (#2) articulate about the sealed and lubricated pivot points (#3) forcing the pusher plates (#4) to press on the friction pads (#5).

The friction pads are held in machined pockets in the base's tower (#6). As the pressure plates exert a squeezing force, the pads pinch the disc (#7). The resulting torque reaction load is directly transmitted from the pads to the tower that is welded to the base (#8).

The caliper arms do not carry the torque reaction load. This allows them to easily accommodate the axial movement of the DC motor.

When power is applied to the coil, the armature is attracted towards the magnet thus collapsing the spring. This allows the caliper arms to open thereby removing the squeezing force on the pads. In this state, the friction pads account for negligible drag.

The disc has far greater exposed swept area than a drum thus its energy dissipation capability is far superior to a drum. This allows the brake to operate cooler and avoid fade problems.

Discs are far less susceptible to heat checking because they absorb energy from both sides, therefore avoiding high thermal stresses common in brake drums.

WHEN CONVERTING

CDB-A brakes directly replace drum brakes. They have the same mounting footprint and torque capacity as drum brakes. When converting, it is critical that the disc's centerline is in the same position as the drum's centerline. (see sketch)

* If the installation conforms to AISE's dimensional standard for DC mill motors, then when ordering all that is required is the DC mill motor number and the existing electrical coil specifications. In all other installations, please provide a drawing of the existing brake wheel.

| DIMENSIONAL DATA | | |
|-------------------------------|----------|----------|
| | CDB1924A | CDB2329A |
| Diameter | 24" | 29" |
| Thickness | 1" | 1" |
| A. Length thru Bore | | |
| Motor Size: 610/810 | 4.5 | |
| 612/812 | 5.0 | |
| 614/814 | 5.0 | 5.0 |
| 616/816 | 5.5 | 5.5 |
| 618/818 | | 6.0 |
| 620/820 | | 6.75 |
| B. Bore | | |
| Motor Size: 610/810 | 3.25 | |
| 612/812 | 3.625 | |
| 614/814 | 4.25 | 4.25 |
| 616/816 | 4.625 | 4.625 |
| 618/818 | | 5.0 |
| 620/820 | | 5.875 |
| O. Centerline Distance | | |
| Motor Size: 610/810 | 7.50 | |
| 612/812 | 7.50 | |
| 614/814 | 7.50 | 8.25 |
| 616/816 | 7.50 | 8.25 |
| 618/818 | | 8.75 |
| 620/820 | | 9.75 |

Single-acting caliper disc brakes impose a bending moment. Shafting should be reviewed prior to installation. Consult PT Tech.

In most cases, PT Tech can suggest mounting adaptations for non-standard drum brakes. Consult PT Tech.

OTHER PRODUCTS

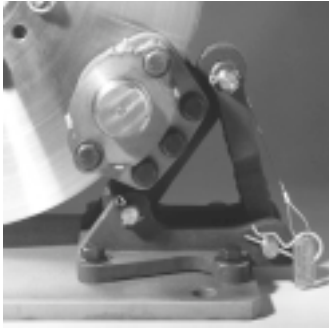

HCDB BRAKES

PT Tech's HCDB brakes directly replace existing 10, 14, and 18" hydraulic drum-style bridge brakes without modification to the installation. Designed to operate with the existing foot pedal, it produces comparable torque for the same applied pedal force. Wear compensating feature reduces maintenance time.

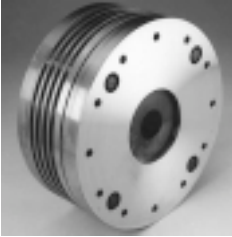

FMD SERIES

PT Tech's FMD series is a friction-type multiple disc torque limiter for high horsepower, high energy and/or limited space applications. Used on applications ranging from main rolling mill drives to crop shears to protect against damaging shockloads. They can be machined to

accept a wide range of couplings from universal joint spindles to elastomeric couplings. The FMD series requires no maintenance and no adjusting throughout its wear life. The torque setting is controlled by the number and strength of spring sub-assemblies and is tamper resistant.

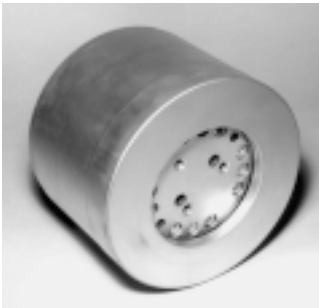

CMD TORQUE LIMITERS

PT Tech's CMD torque limiters are custom designed for flatteners and levelers. Installed on the distribution gearbox output shafts, they protect the drive spindles from damaging overloads. CMDs also evenly distribute the load among the rolls thus helping to improve leveler performance.

APPLICATION ASSISTANCE

PT Tech has been analyzing and solving shockload problems for heavy industry since 1980. Our application engineers regularly visit mills to better appreciate the problems that plant engineers and maintenance people face when trying to solve a shockload problem.

In addition, PT Tech's application engineers have two unique tools to assist you. First, our test stands can simulate the inertia shockload up to that of a #820 DC mill motor in the attempt to better understand how a torque limiter will perform in your application. Second, using thousands of test results, PT Tech has developed a computerized selection program that quickly determines the best solution to your shockload problem.



FIELD SERVICE

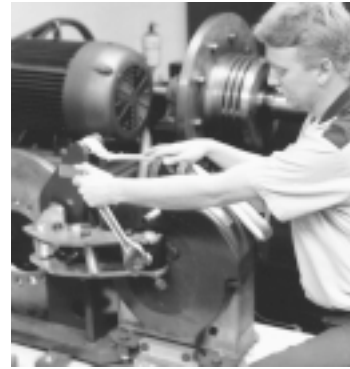

The people at PT Tech who build our disc brakes also go into the field to service them when needed. PT Tech supports its commitment to excellent field service with a large inventory of parts and a 24-hour emergency service hotline. If you need us call 1-800-717-4358.



WARRANTY: PT Tech guarantees all its products will leave the factory in good condition. PT Tech warrants its products against defects in workmanship and material for a period of 365 days (one year) after shipment. Adjustments under this warranty will be made only after completion of inspection of the part or product in PT Tech's factory. PT Tech's liability under the warranty shall extend only to the replacement or correction of any defective part or product determined by PT Tech's inspection as not conforming to this warranty. Under no circumstances shall PT Tech be liable for consequential or incidental damages. This warranty shall not apply to any product which shall have been repaired or altered without PT Tech's knowledge and consent or operated or installed contrary to PT Tech's instruction or subjected to misuse, improper maintenance, or damaged by accident or negligence.

PERFORMANCE ASSURANCE: Rated torque and speeds are provided by PT Tech to assist the buyer in selecting the proper product. In addition, engineering assistance is offered by PT Tech for design and application of custom designed drives. Since the actual performance characteristics of the buyer's equipment cannot be completely analyzed nor duplicated in laboratory tests, performance assurance of all PT Tech products in the buyer's applications is the responsibility of the buyer. Performance assurance is usually accomplished through manufacture of a prototype by PT Tech and a test or qualification program on the part of the buyer.

Rotating equipment is potentially dangerous and should be properly guarded. The user should check all applicable safety codes in his area and provide suitable guards.