

CDB 0812A CALIPER DISC BRAKE

- *Spring applied*
- *Electrically released*
- *Operates in series with DC motors*
- *Installation requires no modification**
- *12" inch disc replaces an 8" wheel*

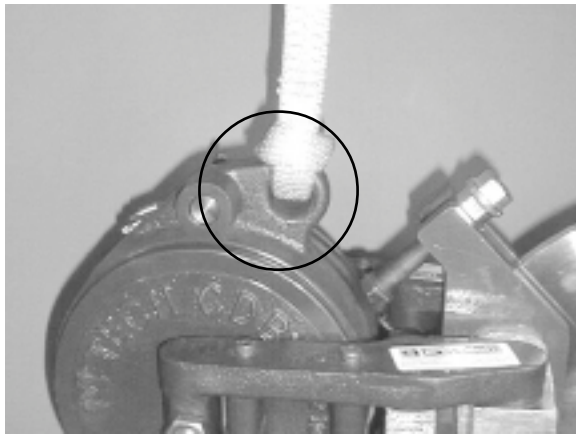

LIFTING MADE EASY

Lifting hole is cast into the magnetic body. It is positioned to provide a balanced load, allowing for ease of brake installation.

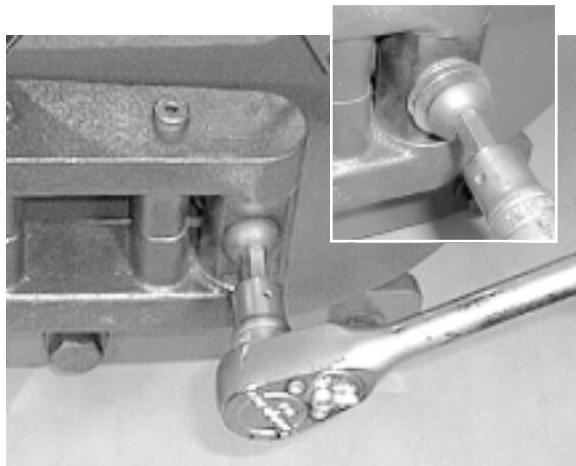

TORQUE ADJUST

Brake torque is adjustable from 100% (100 lb-ft) down to 50% (50 lb-ft) and is visually verifiable. The number of washers under the bolt head determines torque setting.

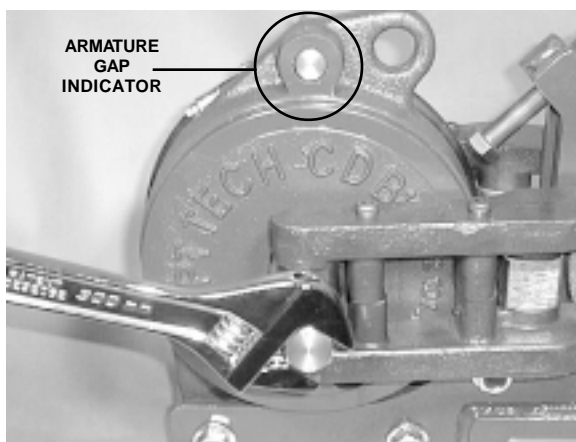

WEAR ADJUST

Adjusting for wear is easy. When the armature gap indicator has recessed approximately 1/16", loosen jam nut, turn adjuster nut until indicator is flush, and then re-tighten jam nut.

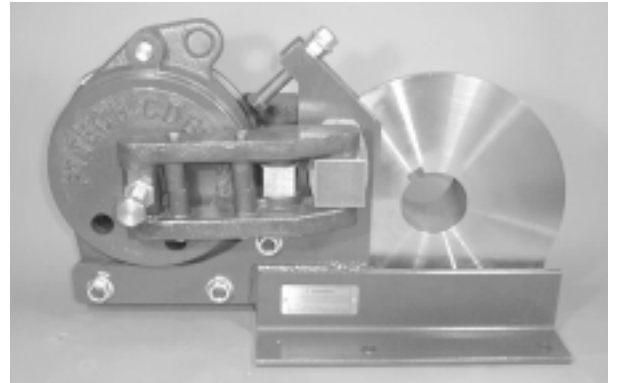

PT Tech's new CDB0812A replaces existing 8" drum brakes and conforms to the new AISE brake standard.

The CDB0812A caliper disc brake provides higher performance and easier maintenance than the drum brakes it replaces. Upgrading your crane with PT Tech's CDB0812A will result in the following advantages.

- 1) Wear adjustment is far easier.
- 2) Less frequent need for wear adjustments.
- 3) Improved wear life.
- 4) Replacing friction pucks is substantially quicker.
- 5) A set of friction pucks weighs only 4½ pounds.
- 6) Eliminates drag and slip problems due to drum thermal expansion.
- 7) Significantly better resistance to heat checking.

PT Tech supports its commitment to excellent field service with a large inventory of parts and a 24-hour emergency service hotline at **800-717-4358**.

MAXIMUM TORQUE (lb-ft)			
SERIES WOUND		SHUNT WOUND	
½ hour	1 hour	½ hour	1 hour
100	65	100	75

Torque is adjustable from 100 down to 50 lb-ft.

 <small>POWER TRANSMISSION TECHNOLOGY INC.</small>	1441 WOLF CREEK TRAIL • P.O. BOX 305 SHARON CENTER, OH 44274-0305 USA TEL (330) 239-4933 FAX (330) 239-2012		
	CDB0812A Caliper Disc Brake		
10/00			CDB0812A

www.pttech.com

CDB 0812A

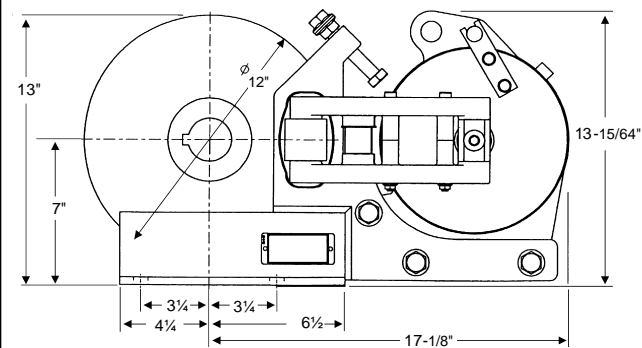
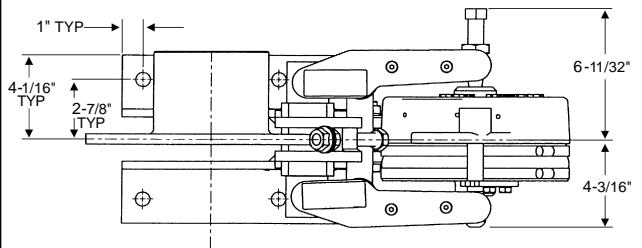

COMPARISON

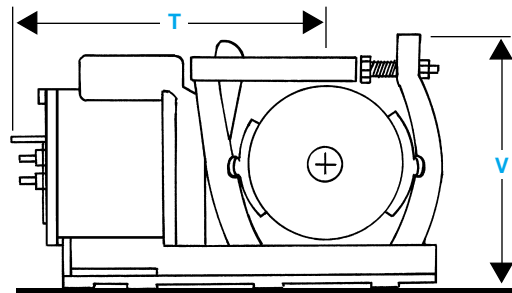
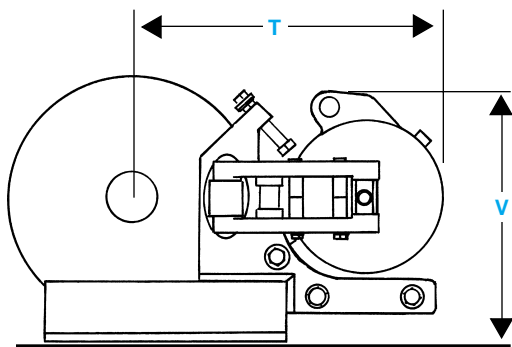

	T LENGTH	V HEIGHT
PT Tech®	17.2	13.3
Cutler/Hammer®	16.8	13.6
Square-D®	17.7	13.8
P & H®	17.4	13.3

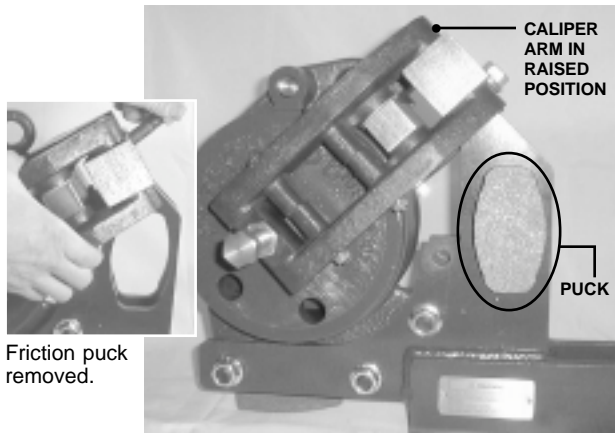

FRICITION MATERIAL REPLACEMENT

Caliper arms swing up exposing friction pucks for easy removal and replacement.



ARM DESIGN

Floating arm design allows for axial movement of DC motors. This prevents drag problems that are common to directly applied caliper disc hoist brakes.

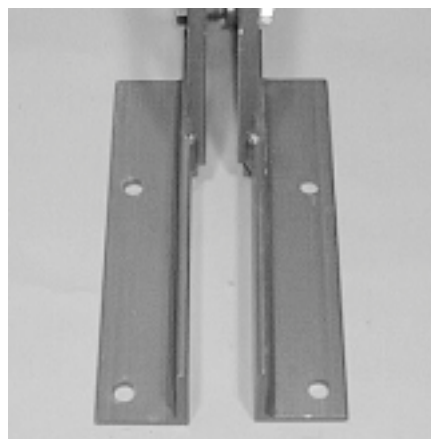

PATENTED SLOTTED BASE

Slotted base allows the CDB0812A to be installed fully assembled. Installation requires no modification. Mounting bolt hole pattern matches existing drum brake and conforms to the new AISE brake standard.

U.S. PATENT NO. 5,582,277. OTHER PATENTS PENDING.

Cutler-Hammer® is a registered trademark of Eaton Corp., Square-D® is a registered trademark of Square-D Corp., P-H® is a registered trademark of Harnischfeger Corp.

CDB0812A CALIPER DISC BRAKE

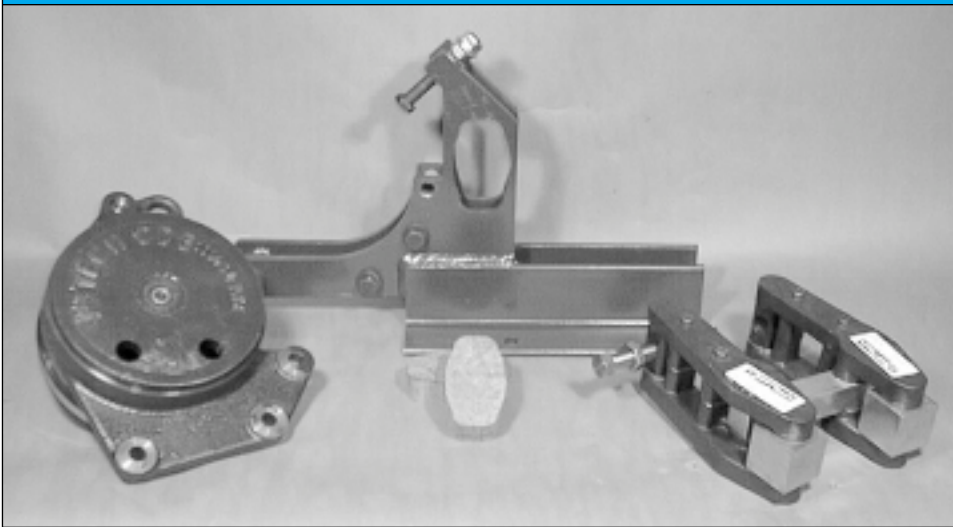

The simple and rugged design makes the new CDB0812A well suited for North American steel mills. There are four major components to the brake: coil, arms, base, and friction pucks.

The arms, base, and friction pucks are similar to PT Tech's other CDB brakes, but the coil is entirely new. It greatly simplifies the design and reduces the total number of parts.

The coil is potted into a magnetic body. Coils are avail-

able to operate in series with DC mill motors or in shunt circuits. The size and shape of the coil/magnetic body was designed using sophisticated computer software. The software optimizes the flux density without causing a heat problem.

The coil/magnetic body is connected to the base on 3 bolts. On top of the magnetic body is an armature gap indicator and a lifting lug. When the indicator has recessed 1/16," the brake requires

adjusting. Adjusting for wear is a two-minute job. (see photo and description on other side).

The lifting hole is positioned to provide a balanced brake assembly. This helps to make installation easy.

There is a friction puck wear adjusting bolt on one side and a torque adjusting bolt on the other. The wear adjuster bolt has a hex head requiring a 12" adjustable wrench. The torque adjusting bolt is a button head requiring a 3/8" Allen wrench. Having different types of bolts helps to eliminate mistakes when making adjustments.

The patented slotted base allows for ease of installation and removal. Like PT Tech's other CDB brakes, the base's tower has machined pockets to hold the friction pucks. During actuation the tower takes the reaction load allowing the arms to move freely to accommodate axial motor movement.

The CDB0812A uses only two pucks. A set of pucks weighs 4½ lbs. Replacing worn friction material takes less than 10 minutes.

HOW IT WORKS

The CDB0812A is spring applied and electrically released. When power is turned off, the torque spring assembly pushes the armature (#1) away from the magnetic body (#2). This movement spreads the arms out. The caliper arms articulate about pivot points (#3) forcing the pusher plates to press on the friction pucks.

Friction pucks (#4) are held in machined pockets in the base's tower (#5). As the pusher plates (#6) exert a squeezing force, the pucks pinch the disc. The resulting torque reaction

load is directly transmitted from the pucks to the base's tower.

The caliper arms do not carry the torque reaction load. This allows them to easily accommodate the axial movement of the DC motor thus avoiding drag problems that are common to directly applied caliper disc brakes on hoists.

When power is applied, the armature is attracted to the magnetic body thus collapsing the torque spring. This allows the caliper arms to open thereby releasing the disc.

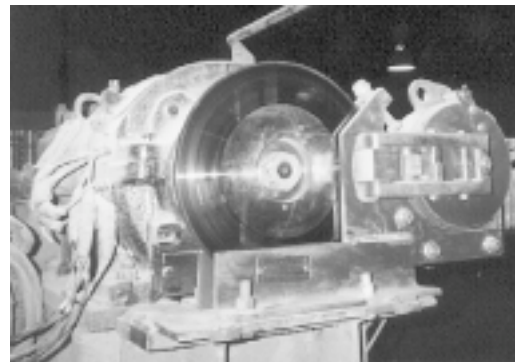
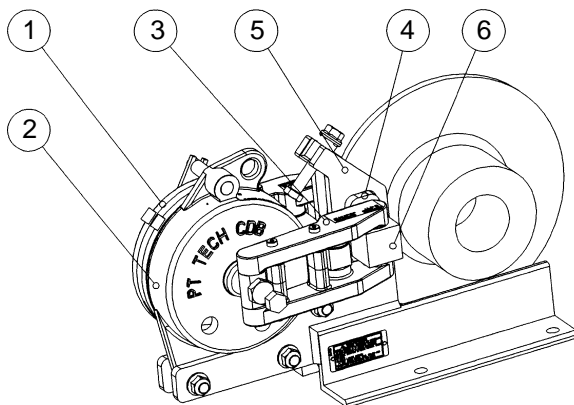

Trolley Drive Brake

DISC DIMENSIONS

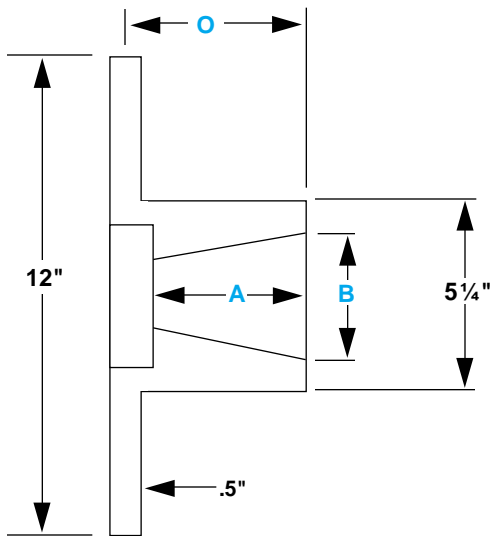

A. LENGTH THRU BORE	
602 and 802	3
603 and 803	3.5
604 and 804	3.5
B. BORE	
602 and 802	1.75
603 and 803	2
604 and 804	2
O. END TO DISC $\text{\textcircled{C}}$	
602 and 802	4
603 and 803	4
604 and 804	4

WHEN CONVERTING

The CDB0812A directly replaces an 8" drum brake. It has the same mounting footprint and torque capacity as an 8" drum brake. When converting, it is critical that the disc's centerline is in the same position as the drum's centerline. (see sketch)

* If the installation conforms to AISE's dimensional standard for DC mill motors, then when ordering all that is required is the DC mill motor number and existing electrical coil specifications. In all other installations, please provide a drawing of the existing brake wheel.

Single-acting caliper disc brakes impose a bending moment. Shafting should be reviewed prior to installation. Consult PT Tech.

In most cases, PT Tech can suggest mounting adaptations for non-standard drum brakes. Consult PT Tech.

APPLICATION ASSISTANCE

PT Tech has been analyzing and solving shockload problems for heavy industry since 1980. Our application engineers regularly visit mills to better appreciate the problems that plant engineers and maintenance people face when trying to solve a shockload problem. In addition, PT Tech's application engineers have two unique tools to assist you. First, our test stands can simulate the inertia shockload up to that of a #820 DC mill motor in the attempt to better understand how a torque limiter will perform in your application. Second, using thousands of test results, PT Tech has developed a computerized selection program that quickly determines the best solution to your shockload problem.

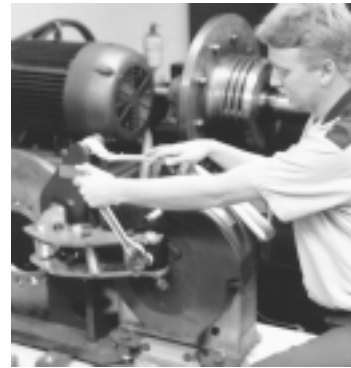

FIELD SERVICE

The people at PT Tech who build our disc brakes also go into the field to service them when needed. PT Tech supports its commitment to excellent field service with a large inventory of parts and a 24-hour emergency service hotline. If you need us call 800-717-4358.

WARRANTY: PT Tech guarantees all its products will leave the factory in good condition. PT Tech warrants its products against defects in workmanship and material for a period of 365 days (one year) after shipment. Adjustments under this warranty will be made only after completion of inspection of the part or product in PT Tech's factory. PT Tech's liability under the warranty shall extend only to the replacement or correction of any defective part or product determined by PT Tech's inspection as not conforming to this warranty. Under no circumstances shall PT Tech be liable for consequential or incidental damages. This warranty shall not apply to any product which shall have been repaired or altered without PT Tech's knowledge and consent or operated or installed contrary to PT Tech's instruction or subjected to misuse, improper maintenance, or damaged by accident or negligence.

PERFORMANCE ASSURANCE: Rated torque and speeds are provided by PT Tech to assist the buyer in selecting the proper product. In addition, engineering assistance is offered by PT Tech for design and application of custom designed drives. Since the actual performance characteristics of the buyer's equipment cannot be completely analyzed nor duplicated in laboratory tests, performance assurance of all PT Tech products in the buyer's applications is the responsibility of the buyer. Performance assurance is usually accomplished through manufacture of a prototype by PT Tech and a test or qualification program on the part of the buyer.

Rotating equipment is potentially dangerous and should be properly guarded. The user should check all applicable safety codes in his area and provide suitable guards.